

CUSTOMER	CATALOG #	W. O. #	DATE ISSUED	DATE REQD	QTY. EA. PER UNIT	W. O. QTY. REQD	FINISH	DRAWN BY	DATE	ASSY. #	DRAWING #
JARDINE	18-1017-524-02				1			T. MASTELL	10.16.06	00-200-00032	04-50-42525
								CHK	MATERIAL	CUT LENGTH	
								APPD	DESCRIPTION	CARBON FIBER OUTLET ENDCAP, BOLT-ON STYLE	
								SCALE	FINISH	REF.	
								REV	DESCRIPTION	DATE	
								A	CHANGED SUBASSEMBLY NUMBER	01.16.07	

DIMENSIONS ARE IN INCHES  
TOLERANCES:  
SURFACE FINISH MAX.  $\sqrt{63}$   
FRACTIONAL  $\pm 1/16$ "  
ANGULAR: MACH  $\pm 1$  BEND  $\pm 2$   
TWO PLACE DECIMAL  $\pm .01$   
THREE PLACE DECIMAL  $\pm .005$

OPERATIONS	
1	C.P.I. 5
2	6
3	7
4	8

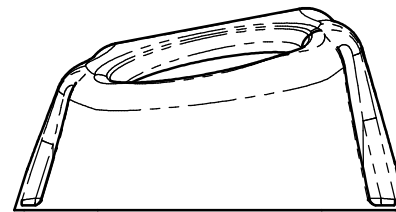
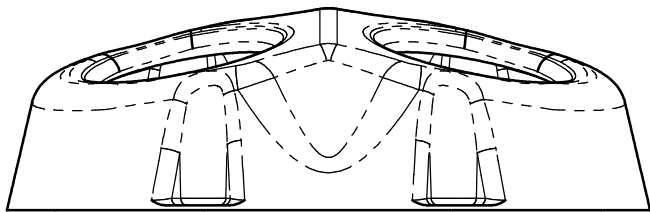
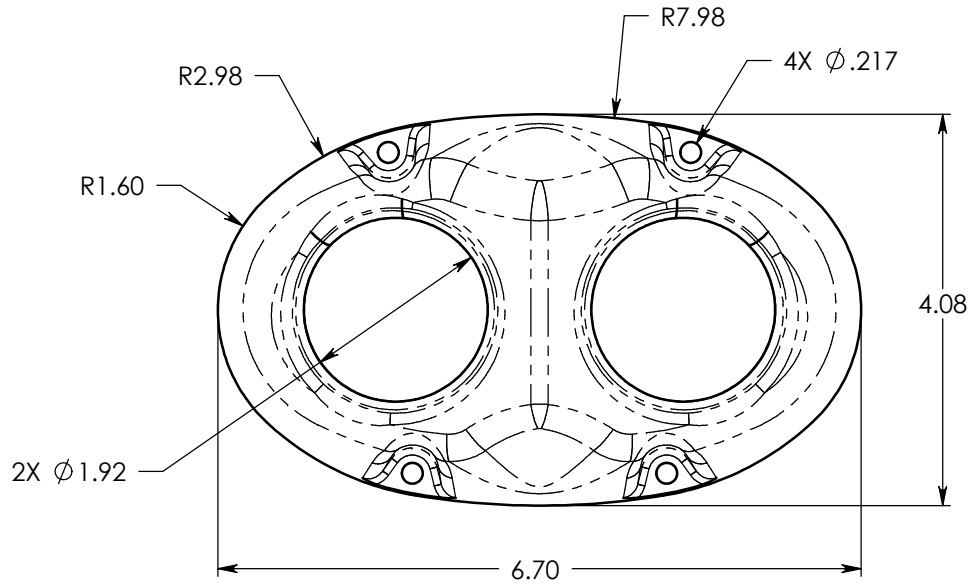

NOTES:

1. MATERIAL IS TO HAVE A FINAL THICKNESS OF .050, CONSTRUCTED OF 2 PLYS, 3K, 2X2 TWILL CARBON FIBER, 350 DEGREE EPOXY RESIN. FILLER MATERIAL IS TO BE FIBERGLASS.