

CUSTOMER	CATALOG #	W. O. #	DATE ISSUED	DATE REQD	QTY. EA. PER UNIT	W. O. QTY. REQD	FINISH	DRAWN BY	DATE	ASSY. #	DRAWING #
JARDINE	18-4018-723-02				1		SCOTCH BRITE	C.V.	01.23.07		00-200-00014
								CHK	MATERIAL	CUT LENGTH	
								APPD	DESCRIPTION		
								RIGHT SIDE ASSEMBLY			
								SCALE	FINISH	REF.	
								1:2	SCOTCH BRITE		
								REV	DESCRIPTION		DATE
								A	INITIAL RELEASE		01.23.07

DIMENSIONS ARE IN INCHES  
TOLERANCES:  
SURFACE FINISH MAX.  $\sqrt{63}$ /  
FRACTIONAL  $\pm 1/16"$   
ANGULAR: MACH  $\pm 1$  BEND  $\pm 2$   
TWO PLACE DECIMAL  $\pm .01$   
THREE PLACE DECIMAL  $\pm .005$

OPERATIONS		
1	WELD	5
2		6
3		7
4		8

ITEM NO.	QTY.	PART NO.	DESCRIPTION
1	1	02-06-42997	RIGHT SLIP-ON TUBE #1
2	1	02-06-42998	RIGHT SLIP-ON TUBE #2
3	1	02-06-42999	RIGHT SLIP-ON TUBE #3
4	1	05-31-42996	MOUNTING BRACKET

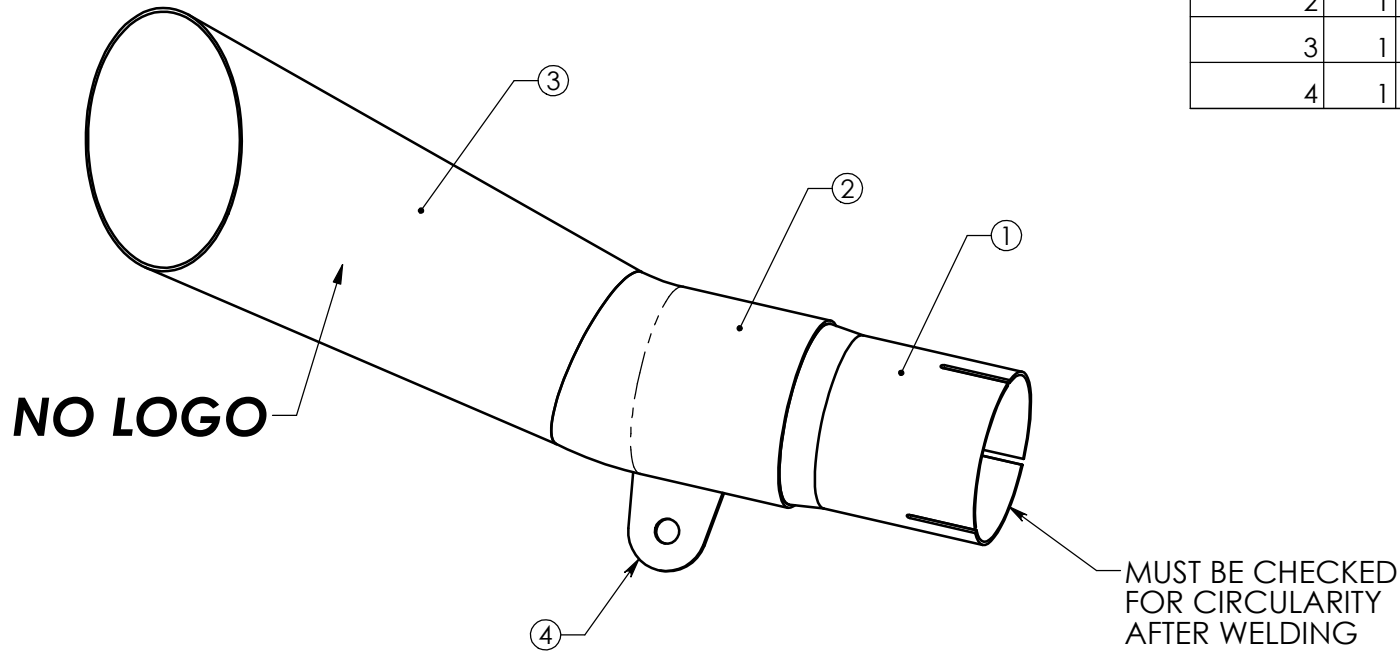

NOTES:

1. ALL WELDS MUST BE FUSE WELDS FOR APPEARANCE
2. SCOTCH BRITE FINISHES SHOULD BE APPLIED PRIOR TO WELDING, DO NOT FINISH THE WELDS