

CUSTOMER	CATALOG #	W. O. #	DATE ISSUED	DATE REQ'D	QTY. EA. PER UNIT	W. O. QTY. REQ'D	FINISH	DRAWN BY	DATE	ASSY. #	DRAWING #	
JARDINE	18-5004-123-02				1		FLAT BLACK	T. MASTELL	04.13.04	00-99-42939	00-200-00010	
								CHK	MATERIAL	CUT LENGTH		
								APPD	DESCRIPTION			
								RIGHT SIDE FAIRING BRACKET ASSEMBLY				
								SCALE	FINISH	REF.		
								N.T.S.	FLAT BLACK POWDER COAT			
								REV	DESCRIPTION	DATE		
								A	ADDED SUPPORT BRACKET, CHANGED FINISH	09.22.04		

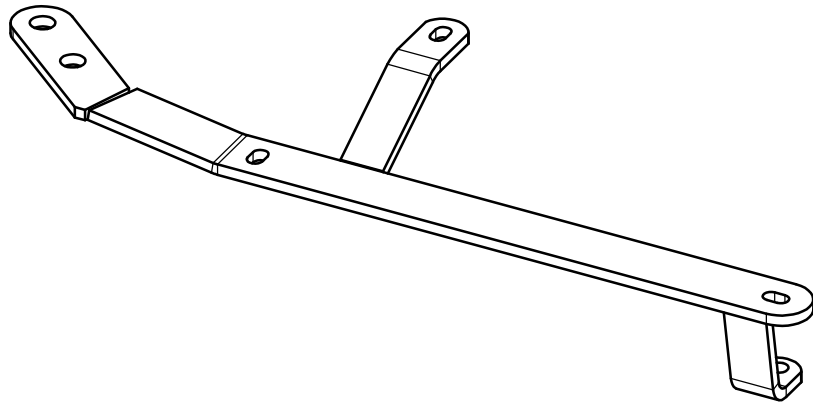

ITEM NO.	QTY.	PART NO.	DESCRIPTION
1	1	39452	FAIRING BRACKET SECTION #1
2	1	39453	FAIRING BRACKET SECTION #2
3	1	39454	FAIRING BRACKET SECTION #3
4	1	39902	FAIRING BRACKET SECTION #4

