

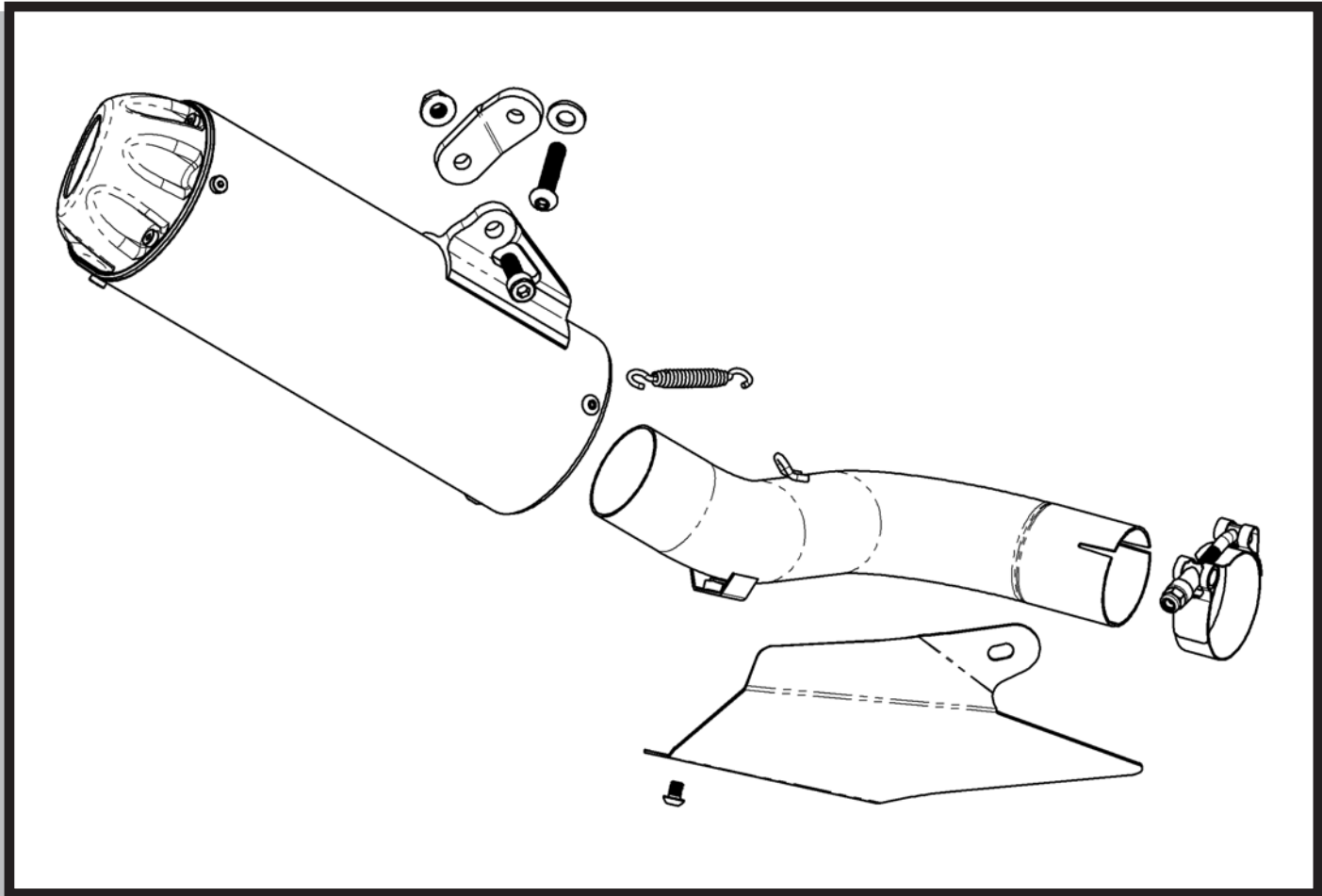

19-1024-323-02

RT5 SLIP-ON EXHAUST, SS/CARBON

HONDA CBR1000RR
2008



PARTS INCLUDED

Ref.	Part Number	Description	Qty
1)	00-200-01172	Slip-on Midpipe Assembly	1
2)	00-200-01175	RT5 Muffler, Carbon Fiber	1
3)	05-31-44488	Lower Fairing Cover	1
4)	04-24-44478	Muffler Adapter Bracket	1
5)	01-510812545-SS	M8-1.25x45mm Socket Button Head Bolt	1
6)	01-520812525-SS	M8-1.25x25mm Socket Head Bolt	1
7)	01-510610008-SS	M6-1.00x8mm Socket Button Head Bolt	1
8)	01-7408125-27	M8-1.25 Hex Flange Nut	1
9)	01-7808-27	8mm Flat Washer	1
10)	07-41-40004	Dual Swivel Spring, Short	1
11)	07-38-42062-35	T-Bolt Clamp	1

08-50-44504 REV. A

19-1024-323-02

RT5 SLIP-ON EXHAUST, SS/CARBON

HONDA CBR1000RR
2008

TOOLS REQUIRED

Ref.	Description
1)	3/8" Drive Ratchet
2)	3" Extension
3)	8mm Socket
4)	10mm Socket
5)	12mm Socket
6)	Phillips Screwdriver
7)	5mm Allen Socket
8)	8mm Allen Socket
9)	8mm Wrench
10)	11mm Wrench
11)	Torque Wrench
12)	Spring Tool or Needlenose Pliers

INSTALLATION INSTRUCTIONS

NOTE: Make sure the motorcycle is cool and secure on a service lift or stand before attempting any installation.

- 1) Loosen the stock muffler inlet clamp bolt. See Figure #1
- 2) Remove the nut that secures the stock muffler to the right side driver footpeg. Do not remove the bolt yet. See Figure #2
- 3) Depress and remove three plastic pin fasteners located behind the right side passenger footpeg. Remove the plastic cover exposing the exhaust butterfly valve actuator. See Figure #3
- 4) Disconnect the cable from the actuator body. See Figure #4
- 5) Remove the bolt securing the rear brake reservoir to the right side driver footpeg. This will allow access to remove the butterfly cable from the motorcycle.
- 6) Remove the bolt the stock muffler is still attached to, and remove the complete stock muffler assembly. Feed the cable out as you remove the muffler.



FIGURE #1

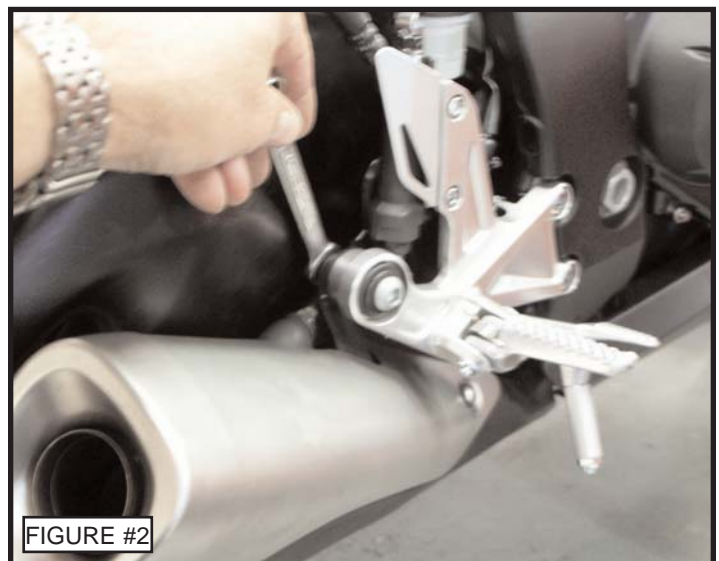

FIGURE #2

19-1024-323-02

RT5 SLIP-ON EXHAUST, SS/CARBON

HONDA CBR1000RR
2008

INSTALLATION INSTRUCTIONS

- 7) Reattach the rear brake reservoir to the driver footpeg mount.
- 8) Reattach the plastic cover over the butterfly valve actuator.
- 9) Slide the new midpipe into the RT5 muffler as shown. Secure the muffler to the midpipe using the supplied swivel spring. See Figure #5
- 10) Slide the supplied t-bolt clamp onto the midpipe inlet. Do not tighten at this time. See Figure #5
- 11) Using the supplied M8-1.25x45mm socket button head bolt, 8mm flat washer, and the stock nut, secure the supplied muffler adapter bracket to the driver footpeg mount as shown. See Figure #6
- 12) Slide the muffler/midpipe assembly onto the stock headpipe outlet. Position and secure the muffler to the muffler adapter bracket using the supplied M8-1.25 socket head bolt and M8-1.25 hex flange nut. See Figure #7
- 13) Position the exhaust system and fully tighten the t-bolt clamp, then all mounting hardware.
- 14) Remove the lower bolt from right side of the fairing that is closest to the rear of the motorcycle. See Figure #8
- 15) Place the supplied fairing cover between the fairing and frame. Secure the fairing cover to the exhaust and frame using the original fairing bolt and the supplied M6-1.0x8mm socket button head bolt. See Figure #9

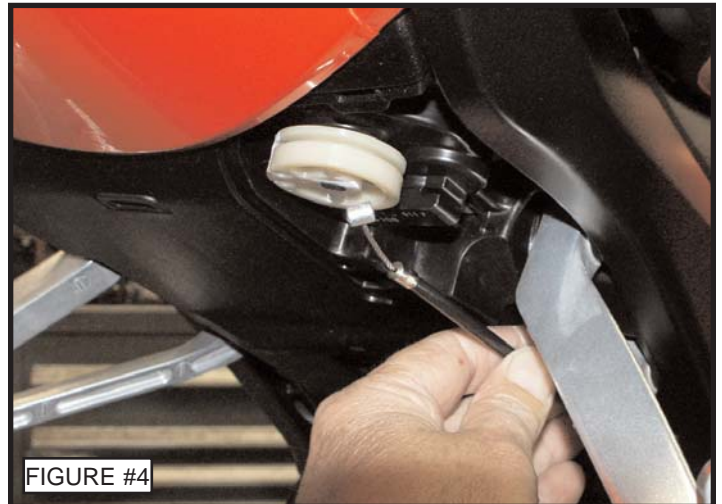

19-1024-123-02

RT5 SLIP-ON EXHAUST, SS/ALUM

HONDA CBR1000RR
2008

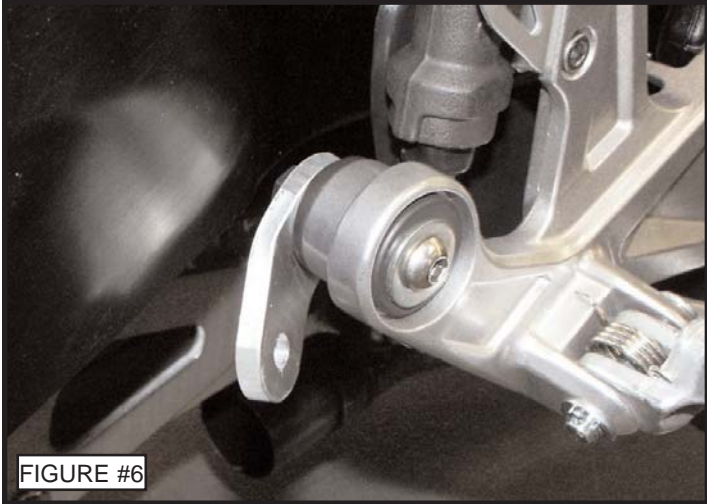

FIGURE #6

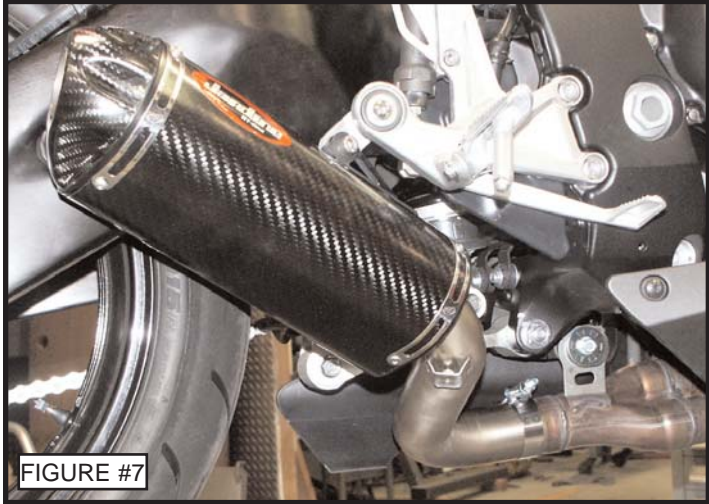

FIGURE #7

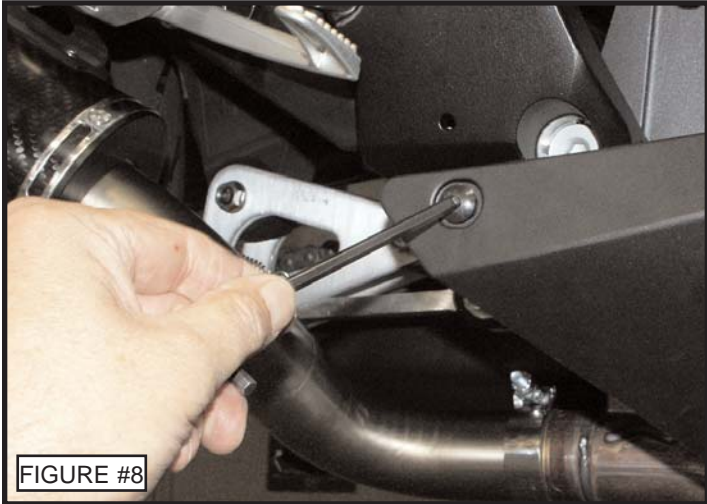

FIGURE #8



FIGURE #9